

Operating Temperature: 0°C~70°C  
 Operating Humidity: 20%~80% (no condensation)  
 Storage Temperature: -25°C~85°C  
 Storage Humidity: 20%~80% (no condensation)

L:  
 CBL-43USPD302MB-3m 3000mm±20mm

No	MATERIALS LIST:
1.	CABLE:UL20276 (1P*30SC#+D+AL+Mylar)*2C+1P*32#+1C*24 OD:4.3mm PVC JACKET COLOR:BLUE
2.	CONNECTOR:USB 3.0 A/M, 9P, BLUE INSULATOR SOLDER TYPE, NICKEL PLATED SHELL
3.	CONNECTOR:USB 3.0 MicroB/M, 10P, BLACK INSULATOR SOLDER TYPE, NICKEL PLATED SHELL
4.	ABS ASSEMBLY HOUSING,BLUE COLOR

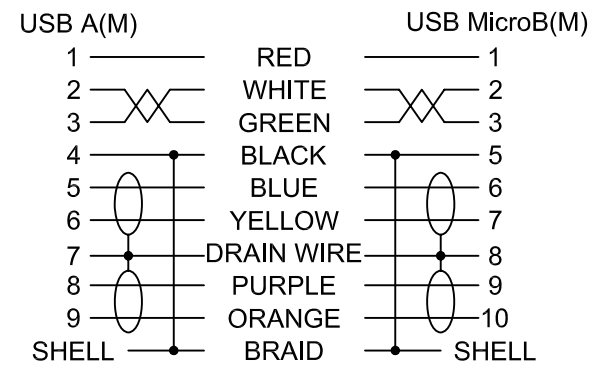

Jargy part no.	Client part no.	Approved	SCALE	UNIT
CBL-43USPD302MB-Xm				mm
Drawing Name		Drawn	Date	REV.
USB 3.0 A to Micro-B Cable M/M				1.0

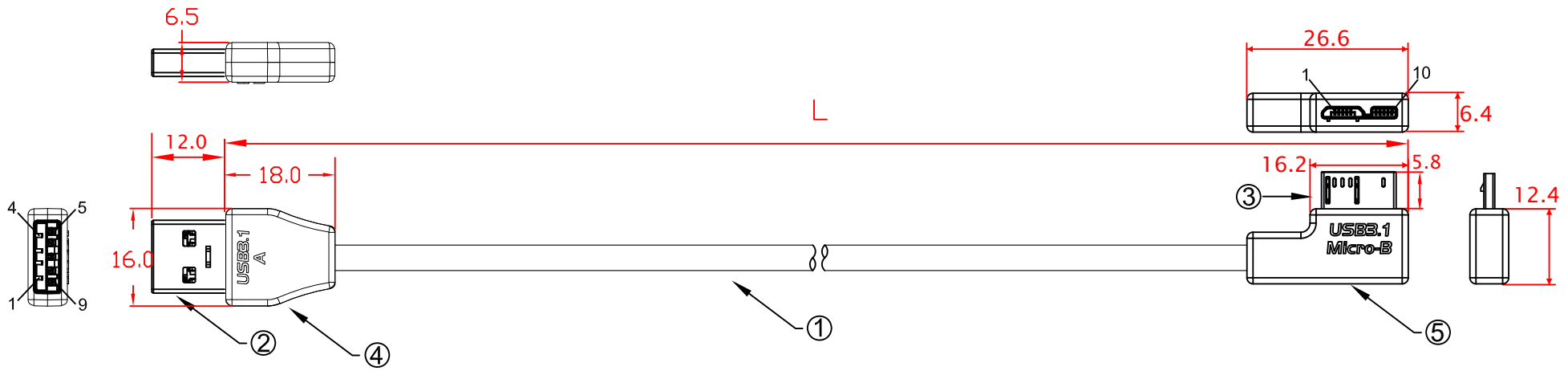

Operating Temperature: 0°C~70°C  
 Operating Humidity: 20%~80% (no condensation)  
 Storage Temperature: -25°C~85°C  
 Storage Humidity: 20%~80% (no condensation)

L:  
 CBL-43USPD302MB-3mLA      3000mm±20mm

No	MATERIALS LIST:
1.	CABLE:UL2725 (32AWG*1PR+D+AM)x2C+32AWG*1PR+24AWG*1C+AM+B OD:4.2mm PVC JACKET COLOR:BLUE
2.	CONNECTOR:USB 3.0 A/M, 9P, BLUE INSULATOR SOLDER TYPE, NICKEL PLATED SHELL
3.	CONNECTOR:USB 3.0 MicroB/M, 10P, BLACK INSULATOR SOLDER TYPE, NICKEL PLATED SHELL
4.	ABS ASSEMBLY HOUSING,BLUE COLOR
5.	PVC MOLDED HOUSING, BLUE COLOR

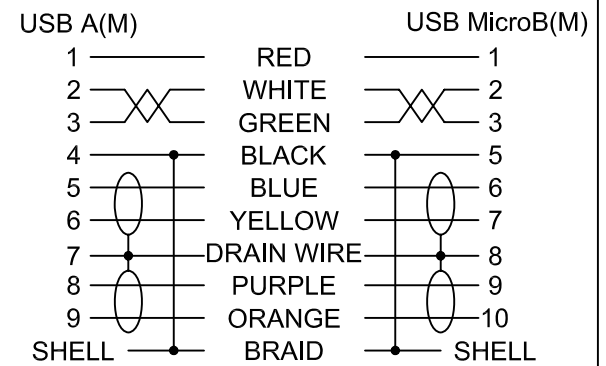

Jargy part no.	Client part no.	Approved	SCALE	UNIT
CBL-43USPD302MB-XmLA				mm
Drawing Name		Drawn	Date	REV.
USB 3.0 A to Micro-B Cable M/M				1.0

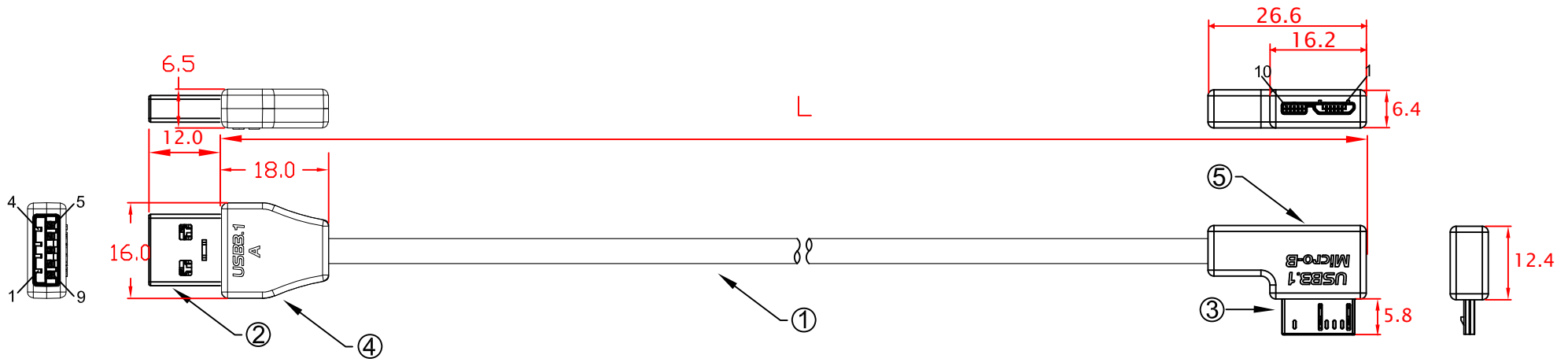

Operating Temperature: 0°C~70°C  
 Operating Humidity: 20%~80% (no condensation)  
 Storage Temperature: -25°C~85°C  
 Storage Humidity: 20%~80% (no condensation)

L:  
 CBL-43USPD302MB-3mRA 3000mm±20mm

No	MATERIALS LIST:
1.	CABLE:UL20276 (1P*30SC#+D+AL+Mylar)*2C+1P*32#+1C*24 OD:4.3mm PVC JACKET COLOR:BLUE
2.	CONNECTOR:USB 3.0 A/M, 9P, BLUE INSULATOR SOLDER TYPE, NICKEL PLATED SHELL
3.	CONNECTOR:USB 3.0 MicroB/M, 10P, BLACK INSULATOR SOLDER TYPE, NICKEL PLATED SHELL
4.	ABS ASSEMBLY HOUSING,BLUE COLOR
5.	PVC MOLDED HOUSING, BLUE COLOR

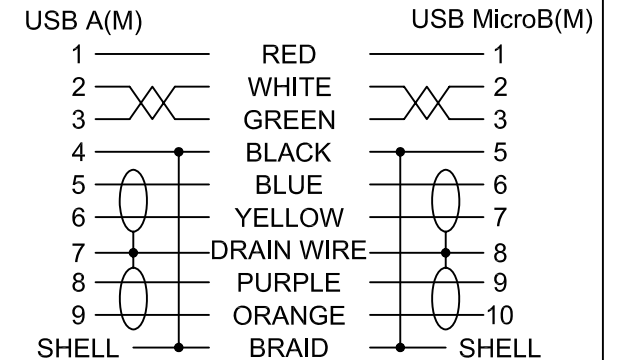

Jargy part no.	Client part no.	Approved	SCALE	UNIT
CBL-43USPD302MB-XmRA				mm
Drawing Name		Drawn	Date	REV.
USB 3.0 A to Micro-B Cable M/M				1.0

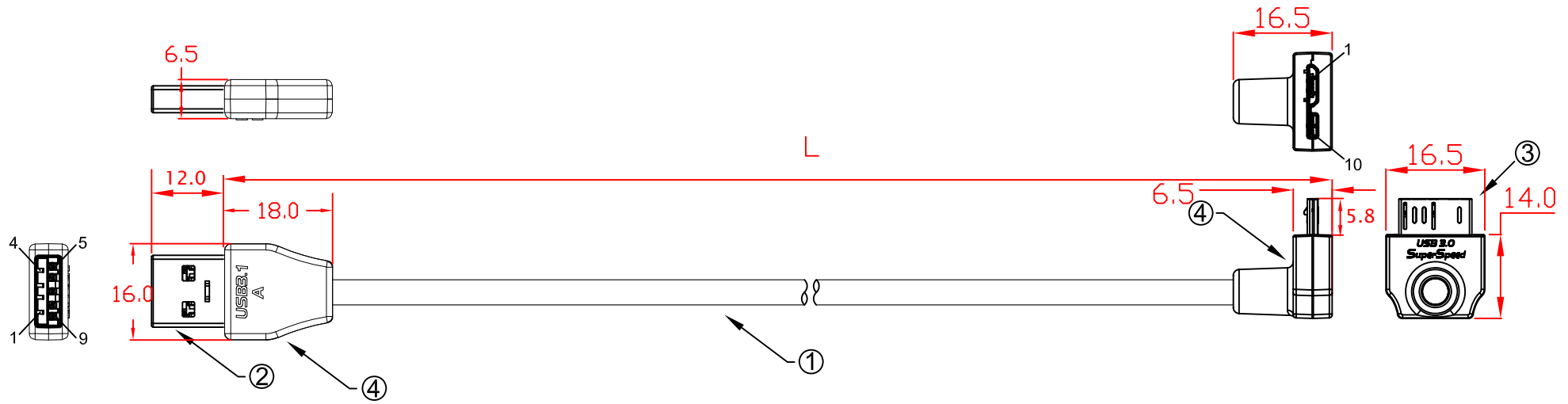

Operating Temperature: 0°C~70°C  
 Operating Humidity: 20%~80% (no condensation)  
 Storage Temperature: -25°C~85°C  
 Storage Humidity: 20%~80% (no condensation)

L:  
 CBL-43USPD302MB-3mUA 3000mm±20mm

No	MATERIALS LIST:
1.	CABLE:UL20276 (1P*30SC#+D+AL+Mylar)*2C+1P*32#+1C*24 OD:4.3mm PVC JACKET COLOR:BLUE
2.	CONNECTOR:USB 3.0 A/M, 9P, BLUE INSULATOR SOLDER TYPE, NICKEL PLATED SHELL
3.	CONNECTOR:USB 3.0 MicroB/M, 10P, BLACK INSULATOR SOLDER TYPE, NICKEL PLATED SHELL
4.	ABS ASSEMBLY HOUSING,BLUE COLOR

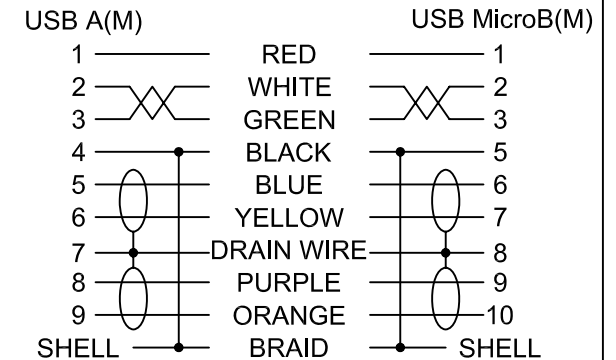

Jargy part no.	Client part no.	Approved	SCALE	UNIT
CBL-43USPD302MB-XmUA				mm
Drawing Name		Drawn	Date	REV.
USB 3.0 A to Micro-B Cable M/M				1.0

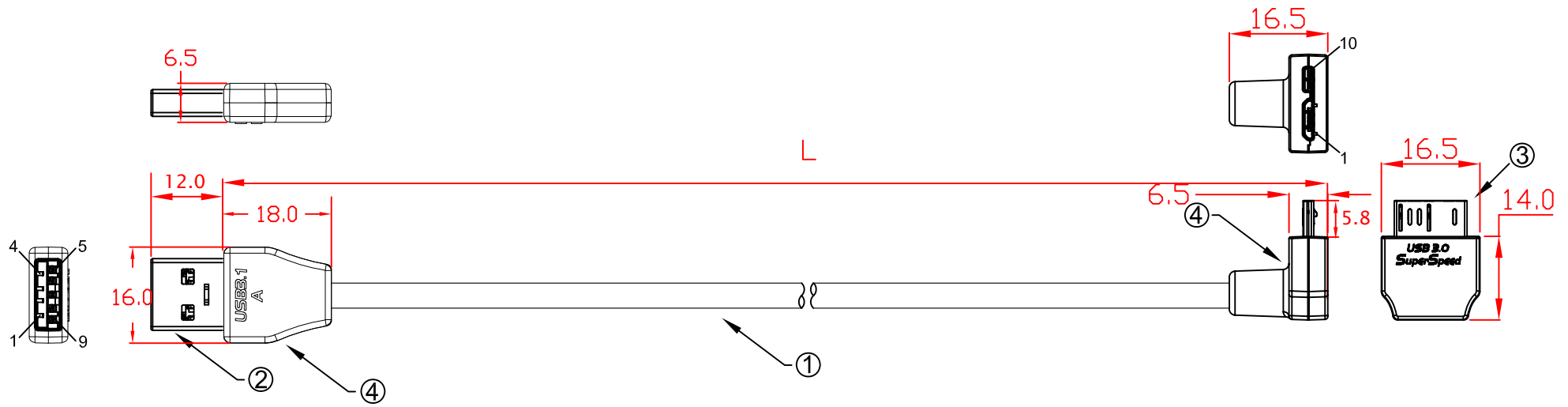

Operating Temperature: 0°C~70°C  
 Operating Humidity: 20%~80% (no condensation)  
 Storage Temperature: -25°C~85°C  
 Storage Humidity: 20%~80% (no condensation)

L:  
 CBL-43USPD302MB-3mDA 3000mm±20mm

No	MATERIALS LIST:
1.	CABLE:UL20276 (1P*30SC#+D+AL+Mylar)*2C+1P*32#+1C*24 OD:4.3mm PVC JACKET COLOR:BLUE
2.	CONNECTOR:USB 3.0 A/M, 9P, BLUE INSULATOR SOLDER TYPE, NICKEL PLATED SHELL
3.	CONNECTOR:USB 3.0 MicroB/M, 10P, BLACK INSULATOR SOLDER TYPE, NICKEL PLATED SHELL
4.	ABS ASSEMBLY HOUSING,BLUE COLOR

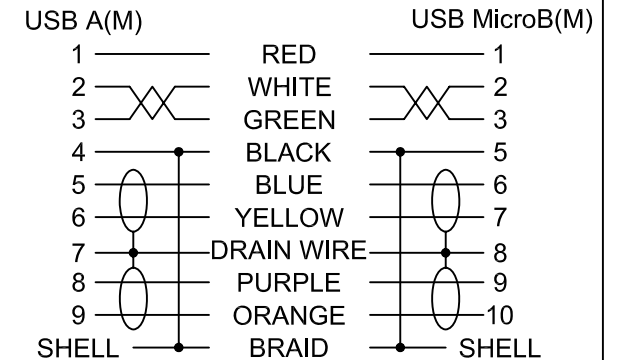

Jargy part no.	Client part no.	Approved	SCALE	UNIT
CBL-43USPD302MB-XmDA				mm
Drawing Name		Drawn	Date	REV.
USB 3.0 A to Micro-B Cable M/M				1.0